

THE LENNOX BOOK

A BETTER PLACE®



LENNOX' MERIT® SERIES

Home Comfort Systems

G43

Direct/Non-Direct Vent
Gas Furnace

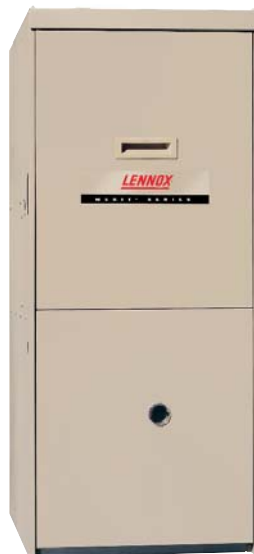

Lennox' Merit® Series G43 Gas Furnace

Lennox makes your HOME...A BETTER Place.®

Excellent efficiency can save you hundreds of dollars each year

ENERGY STAR®-qualified

Durable, high-quality design for long-lasting performance

Upflow configuration allows installation in basements or closets

EFFICIENCY RATING

Up to 92.1% AFUE (Annual Fuel Utilization Efficiency)

WARRANTY

20-year limited warranty on the heat exchanger, 3-year limited warranty on the ignition control, 1-year limited warranty on all remaining covered components.

ECONOMICAL, HIGH-EFFICIENCY GAS HEATING.

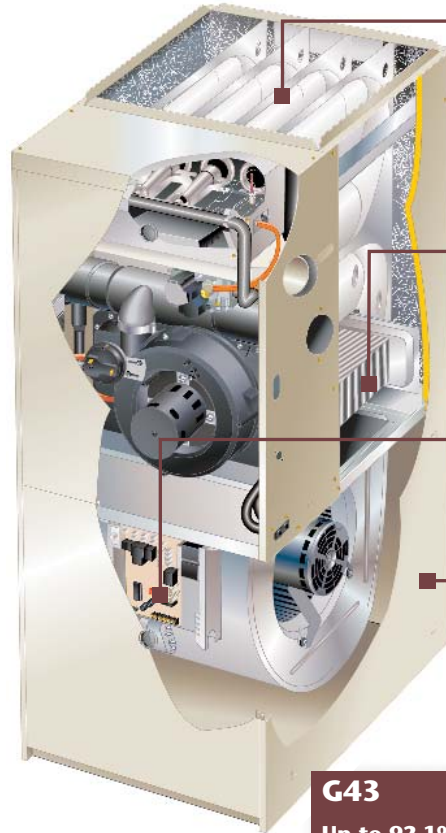

Duralok Plus® Heat Exchanger – Made of patented ArmorTuf™ aluminized steel that's life-tested to 2-1/2 times standard requirements* for long life and durability.

Secondary Heat Exchanger – Allows the furnace to reach high efficiency levels by capturing additional heat.

Integrated Control Board – Provides full control of furnace operation.

Durable Steel Cabinet – Made to last, with a resilient and attractive textured-paint finish.

*ASI Standard Z21.47

G43
Up to 92.1% AFUE

Merit® Series G43 Specifications

G43UF	24B-045	24B-070	36B-070	36C-090
AFUE	90%	90%	92.1%	90%
Input/Output Btuh capacity (kW)	44,000 (12.9) / 40,300 (11.8)	66,000 (19.3) / 59,800 (17.5)	66,000 (19.3) / 62,000 (18.2)	88,000 (25.8) / 82,300 (24.1)
Cooling CFM at 0.5 ESP	760	810	1360	1465
Dimensions HxWxD (in.)	40 x 17-1/2 x 28-1/2	40 x 17-1/2 x 28-1/2	40 x 17-1/2 x 28-1/2	40 x 21 x 28-1/2
HxWxD (mm)	1016 x 446 x 724	1016 x 446 x 724	1016 x 446 x 724	1016 x 533 x 724
G43UF	48C-090	48C-110	60C-110	60D-135
AFUE	92.1%	92.1%	92.1%	92.1%
Input/Output Btuh capacity (kW)	88,000 (25.8) / 83,000 (24.3)	110,000 (32.2) / 104,000 (30.5)	110,000 (32.2) / 104,000 (30.5)	132,000 (38.7) / 124,000 (36.3)
Cooling CFM at 0.5 ESP	1865	1780	2270	2310
Dimensions HxWxD (in.)	40 x 21 x 28-1/2	40 x 21 x 28-1/2	40 x 21 x 28-1/2	40 x 24-1/2 x 28-1/2
HxWxD (mm)	1016 x 533 x 724	1016 x 533 x 724	1016 x 533 x 724	1016 x 622 x 724

Note: Due to Lennox' ongoing commitment to quality, all specifications, ratings and dimensions are subject to change without notice. Warranties noted apply to residential applications only and are limited. Please see actual warranty for details.

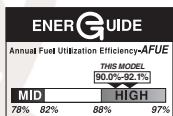

Many Lennox® home comfort systems meet ENERGY STAR® requirements when used with appropriate components. Ask your dealer for details.



Lennox is proud of the fact that these products have earned the Good Housekeeping Seal.



LENNOX® *A better place®*
HOME COMFORT SYSTEMS

(77M40) G43 2/04
PC37970

© Lennox Industries Inc. 2004

Visit us at www.lennox.com, or contact us at 1-800-9-LENNOX.